

True Single-Chip Designs with the Intel[®] Atom[™] Processor E6xx Series System on Chip – ADI’s “Thin E6xx” Offerings Shatter Ultra-Low Cost Barriers

An ADI Engineering Whitepaper

An overview of ADI Engineering’s unique “Thin E6xx” products and how they enable true single chip operation of the new embedded Intel Atom System on Chip, for major reductions in cost, power consumption and size

Copyright © 2010, ADI Engineering, Inc.

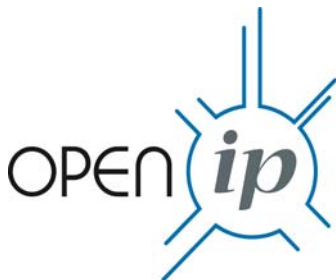

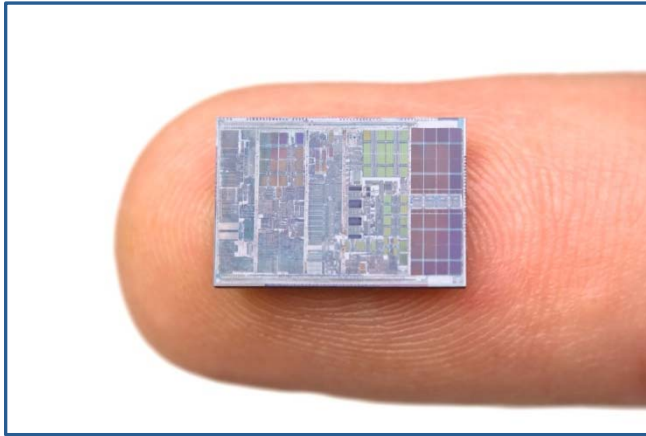

WITH THE RELEASE OF THE INTEL ATOM PROCESSOR E6XX SERIES,

Intel has added a number of useful features to its very popular low-power embedded Atom processor Z5xx series, such as improved graphics performance, a built-in hardware video encoder, and industry-standard PCI Express (PCIe) instead of a proprietary front side bus (FSB) as the primary interface to the CPU. The E6xx processor's use of PCIe as its primary

interface also allows third party silicon vendors to offer application-specific I/O Hub chips ("IOHs"), and developers can also create their own FPGA or ASIC-based custom IOHs.

But the main innovation of the E6xx is that it's Intel's first embedded Atom system on chip (SoC). An IOH such as the Intel EG20T can be used to add USB, SD, SATA and other features when needed, and the open PCIe interface allows third-parties to develop new IOHs targeted to a wide range of applications – in-vehicle entertainment, IP video phones and surveillance, networking and security, storage, and IP media players, to name a few.

The E6xx is Intel's first-generation embedded Atom SoC, raising hopes of delivering the true single-chip savings needed by deeply embedded "thin" applications where Intel Architecture ("IA," or x86) processors are highly desired for their extensive software support, but have long held significant disadvantages in cost, size and power consumption. However, certain issues in the E6xx must be addressed to enable true single-chip operation.

The result: The IOH is mandatory, and the E6xx remains a two-chip CPU chipset, diminishing the anticipated savings in cost, size and power consumption in thin applications.

Why Standard Design Approaches for the E6xx Cannot Achieve Single Chip Operation

To understand how this situation came to be, and how to correct it, we need to examine the specific limitations of the E6xx SoC in thin applications, which are:

- Lack of an on-chip interface for an OS boot device – SATA, SD, PATA, USB, or NAND Flash controller. Intel's E6xx system architecture partitions this function to the IOH. The result is that an IOH is normally required and the E6xx remains a two-chip CPU chipset, negating hopes for true single-chip cost and power savings.

- The need for complex system management and power control hardware and firmware represents a significant added cost for the E6xx compared to competitive non-IA processors.
- The need for BIOS is a burden that only IA processors carry. Cost-sensitive deeply applications typically have no need for a full-function BIOS, which can add a significant per-unit royalty expense.

Deeply embedded device developers are eager to migrate their thin applications to an Intel Atom SoC, but the standard two-chip E6xx architecture does not deliver the full savings that are necessary.

Thin Deeply Embedded Applications for the Intel E6xx

With the rapid growth of IP-based audio/video technologies, a new class of deeply embedded product is emerging to meet pervasive requirements for embedded HD A/V streaming and playback, wired or wireless networking, user interface, security, embedded control, and content management. Applications include digital signage, consumer electronics, video surveillance, in-vehicle infotainment, military, medical, and industrial control. While low-cost ARM processors or ARM+DSP SoCs can meet some of the low-level IP A/V decode requirements, these processors typically fall short of meeting all the higher-level requirements because of their limited performance headroom while performing HD decoding. And software support is a challenge.

ADI has noted a definite trend in the industry where developers are seeking to migrate ever-thinner devices to IA, to gain substantial improvements in performance, scalability, and software support. Key characteristics of these potential thin IA applications include:

- Require high-performance, high-definition A/V decoding or encoding
- Require substantial CPU performance headroom for user interface, networking and wireless, management, control, content management, and other high-level tasks
- Have I/O needs that are rather modest and specifically targeted to the end application, instead of "kitchen sink" collections of non-targeted I/O typical of previous-generation embedded IA products. Often, an Ethernet port or wireless interface, LVDS or HDMI video port, and small handful of other ports are all that is needed.
- Have a strong preference for x86 instruction set compatibility, to tap into the large base of OS's, drivers, middleware, A/V CODECs and media players, and software applications that support IA.
- Have aggressive requirements for production cost, power consumption, and size that cannot be met by traditional multi-chip IA CPU chipsets.
- Frequently require Adobe Flash, which has significant limitations on non-IA processors.

If true single-chip operation of the E6xx SoC could be realized, it would be an ideal solution for these thin, deeply embedded IA applications.

Two examples of thin E6xx applications are shown in Figures 1 and 2. Figure 1 shows an 802.11n-to-HDMI streaming HD media player, and Figure 2 shows an extended-temperature outdoor digital signage controller. Both systems run embedded Linux, both require 1080p HD video decode, both require near-desktop performance with significant headroom while decoding 1080p video, and both must run the latest version of Adobe Flash (10.1). The E6xx is an ideal CPU meeting all the technical requirements, but the conventional two-chip E6xx design approach can exceed BOM cost targets by 50% or more.

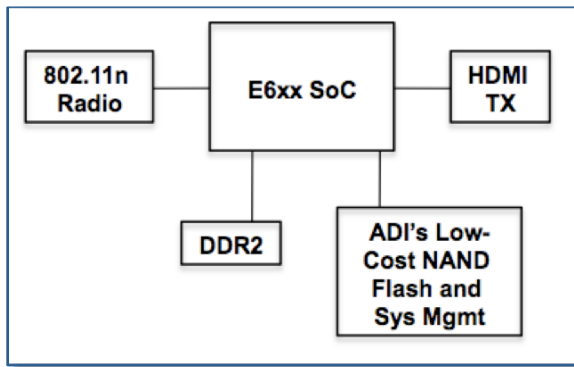

Figure 1: 802.11n-to-HDMI Streaming HD Media Player

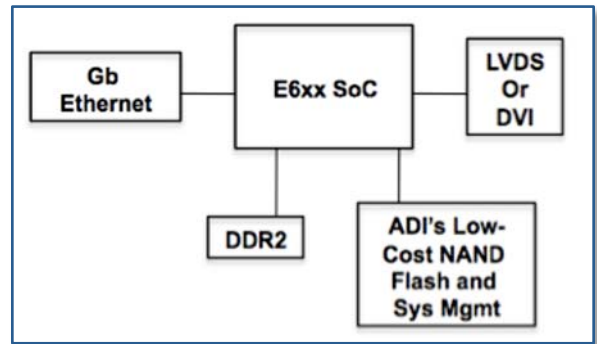

Figure 2: Extended Temperature Digital Signage Controller

ADI's "Thin E6xx" Semi-Custom Designs Shatter the Ultra-Low BOM Cost Barrier

To overcome the cost disadvantages of conventional two-chip E6xx architectures in deeply embedded applications, ADI Engineering has developed a novel "Thin E6xx" approach. ADI's Thin E6xx approach is a fresh, innovative new strategy that departs from conventional thinking to unlock the full potential of the E6xx as a true single-chip Atom SoC with substantial savings in cost, power consumption, and size.

ADI's Thin E6xx offerings include single-chip E6xx commercial off-the-shelf (COTS) single board computers, and rapid time-to-market semi-custom products that are specifically tailored to your application for the ultimate in per-unit cost savings. And for approximately the same per-unit cost as lower-end ARM-based products, ADI's Thin E6xx designs bring the significant advantages of the E6xx in video encode/decode performance, CPU core performance, and networking performance to low-cost thin applications.



With its new approach, ADI can deliver thin E6xx designs that set new standard for embedded Atom BOM cost, power consumption, and size. The unprecedented low BOM cost of ADI's semi-custom thin E6xx designs finally bring the many benefits of the Intel E6xx available to entirely new classes of deeply embedded applications that cannot tolerate the higher costs of multi-chip IA processors.

ADI's Thin E6xx Approach Explained

ADI Engineering's Thin E6xx approach is enabled by three primary technologies pioneered by ADI: A low-cost NAND Flash controller designed and optimized for the E6xx, royalty-free boot loader firmware created using Intel boot loader development kits for the E6xx, and a low-cost E6xx system manager, as explained below.

E6xx NAND Flash Controller

The biggest limitation of the E6xx is the lack of any on-chip non-volatile storage device controller – SATA, PATA, SD, USB, or NAND Flash. While the conventional approach is to simply use the Intel EG20T IOH with the E6xx to add SATA, SD or USB as the OS boot device controller, this also transforms the E6xx into a two-chip CPU chipset with substantial penalties cost, size and power consumption.

ADI has developed a low-cost NAND Flash controller specifically optimized for the E6xx. ADI's design uses a small, low-power, inexpensive CPLD connected to the E6xx LPC bus to serve as a low-level NAND Flash controller, at far lower cost, power and size than the EG20T IOH. Eliminating the IOH causes a ripple effect of other savings throughout the design, such as management and power control circuits and board area. And with four PCIe x1 interfaces, PCIe MiniCard can be used as an expansion card slot, and specifically targeted on-board I/O can be added to match exact needs of each end product at lower overall cost.

Royalty-Free Boot Loader Firmware

Traditional IA-based products, including those based on the E6xx, normally use commercially available BIOS. The history of BIOS is firmly rooted in the evolution of the desktop PC, but in deeply embedded applications – especially those running Linux - BIOS often has little or no intrinsic value. Even worse, BIOS carries a substantial per-unit royalty cost to IA-based designs that isn't incurred by competitive processors. The E6xx is competing in deeply embedded applications with processor architectures that do not require BIOS, and this can represent a significant cost disadvantage.

Intel and ADI are pioneering the use of boot loader development kits to create royalty-free boot loader implementations for the E6xx utilizing new Intel boot loader technologies. Note that boot loaders created using Intel boot loader development kits are not meant to be a full replacement for BIOS, since they cannot boot desktop Windows (WinCE may be OK, though), and do not

offer the extensive configurability, control, and user interface of commercial BIOS offerings. However, for deeply embedded devices running Linux, the E6xx boot loader development kit offers the means to develop a viable alternative to BIOS that removes a significant per-unit cost disadvantage long incurred by IA.

ADI is experienced in the new boot loader development kits from Intel, and uses it to develop royalty-free Linux boot loaders for its COTS and custom E6xx based designs.

Thin E6xx System Manager

E6xx designs normally require a relatively complex system manager to handle power-on sequencing and sleep state and power control. Simply eliminating the EG20T reduces the system management requirements. Further, the need for sleep states and dynamic power control is reduced or eliminated in thin designs, since they have low power consumption to begin with and active power management usually is not needed.

ADI's thin E6xx design approach uses a low-cost, small CPLD to perform system management and power control functions. ADI's system controller is lower cost than conventional designs, and is readily adapted to semi-custom Thin E6xx products.

ADI's Thin E6xx Offerings

ADIs' Thin E6xx offerings are available in two forms from ADI: COTS single board computers (SBCs) and rapid, low-NRE semi-custom designs that are tailored to the specific needs of your application to deliver the ultimate in low production cost.

Thin E6xx-Based "Cinnamon Bay EX SBC"

In Q1 of 2011, ADI will release its new "Cinnamon Bay EX" SBC based on the Intel Atom Processor E6xx series. Cinnamon Bay EX is the next-generation offering in ADI's Cinnamon Bay deeply embedded SBC family, and is form-fit-function compatible with the existing Z5xx-based Cinnamon Bay SBC product line. Cinnamon Bay EX will be available in both 0-70C and true -40-+85C temperature ranges, as well as both full-featured SKUs using the E6xx CPU and EG20T IOH, and "thin" SKUs that omit the EG20T to achieve price points well below other E6xx SBCs.

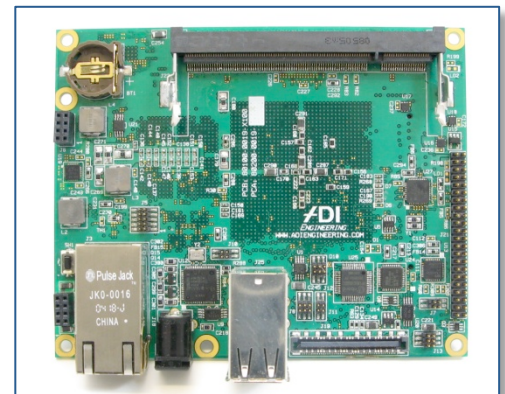

Figure 3: ADI's Cinnamon Bay EX SBC Based on the Intel E6xx Processor

ADI's thin Cinnamon Bay EX SKU eliminates the EG20T IOH and uses a royalty-free Linux boot loader derived from Intel boot loader development kits to offer a lower price point than other SBCs based on the conventional two-chip E6xx design paradigm. An on-board Gb Ethernet port, LVDS video port, and PCI Express MiniCard slot

allow for expandability and the easy addition of a NAND Flash module, boot device controller card or other peripherals.

Rapid Turnaround, Low-NRE Semi-Custom Thin E6xx Designs

For the ultimate in low production cost, ADI's semi-custom Thin E6xx designs can be rapidly developed at low NRE to fit your exact requirements. ADI's semi-custom thin E6xx products set new standards for cost, power and size.

ADI's pre-validated design blocks and rapid-deployment engineering capabilities reduce the NRE, time to market, and risk of the semi-custom design program, and the substantial production cost savings of a true single chip E6xx design tailored to your exact requirements can quickly deliver a large ROI.

"Open IP" Puts Customers in Control

Both thin E6xx offerings from ADI – COTS SBCs and semi-custom designs – are fully supported by ADI's groundbreaking **Open IP** business model of "We Build/You Build" customer-directed manufacturing and IP licensing. With **Open IP**, only ADI gives its customers flexible, open, pre-defined paths to product IP ownership and the power to decide whether to use ADI's manufacturing services or to produce it themselves. Even ADI's COTS products are eligible for **Open IP** licensing and direct customer production. Unlike traditional ODMs and COTS board vendors whose business models rely on preventing customer ownership of product IP, ADI's bold ADI's **Open IP** model eliminates the single-source supplier risks inherent with conventional third-party COTS or semi-custom products.

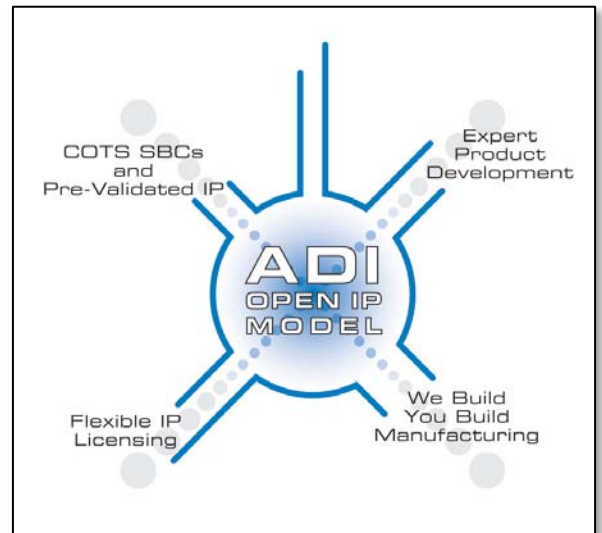

Figure 5: ADI's Open IP Business Model

For more information on ADI's **Thin E6xx Semi-Custom Products**, the upcoming **Cinnamon Bay EX SBC Based on the Intel Atom Processor E6xx Series**, or ADI's **Open IP Business Model**, please contact ADI Engineering at sales@adiengineering.com or +1-434-978-2888.